

NOTES: UNLESS OTHERWISE SPECIFIED

1. SEE DRAWING NO. CB-00292 AND PROCEDURE P-1000 FOR ASSEMBLY AND TEST INSTRUCTION. PROCEDURES AND ASSEMBLY DRAWINGS ARE FOR INTERNAL USE ONLY.
2. ALL TESTING IS PERFORMED IAW BATTERY COUNCIL INTERNATIONAL STANDARDS.
3. DIMENSIONS ARE INCH [MILLIMETER].
4. ABBREVIATION USED IN TITLE IS: SEALED LEAD ACID (SLA).
5. TERMINAL HARDWARE KIT PROVIDED, PART NUMBER 6923 (2 REQD).

REVISIONS			
REV	DESCRIPTION	DATE	APPROVED
B	SEE DCN PVX6480TB	8/10/11	JBT
C	STANDARDIZED ENVELOPE, ADDED NOTE 5	7/29/20	PH
D	REVISED CONTAINER	1/4/22	PH

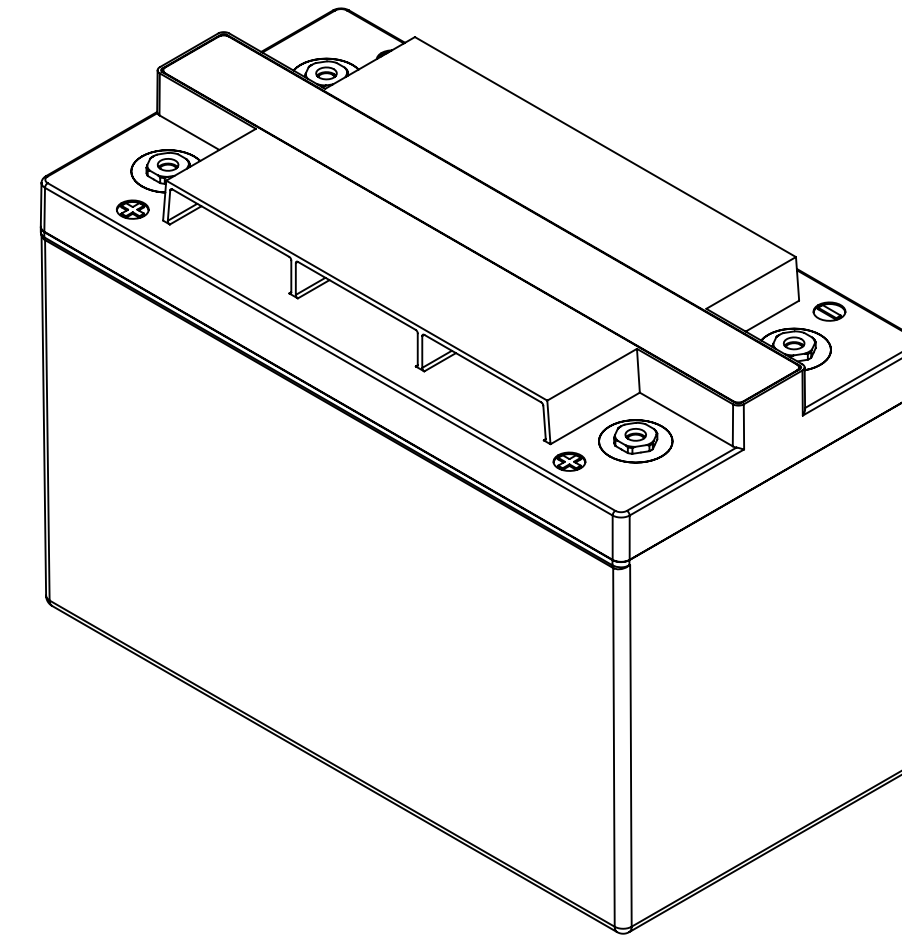
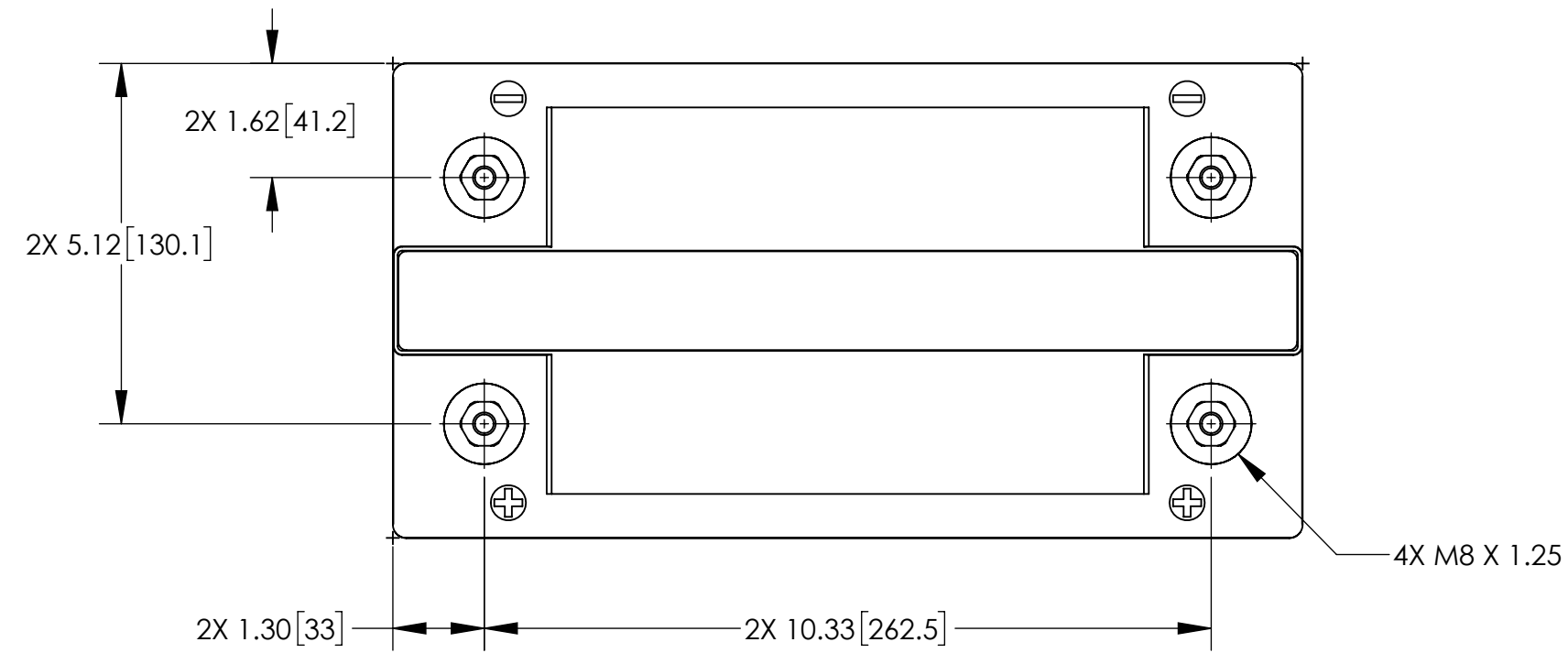

REFERENCE VIEW

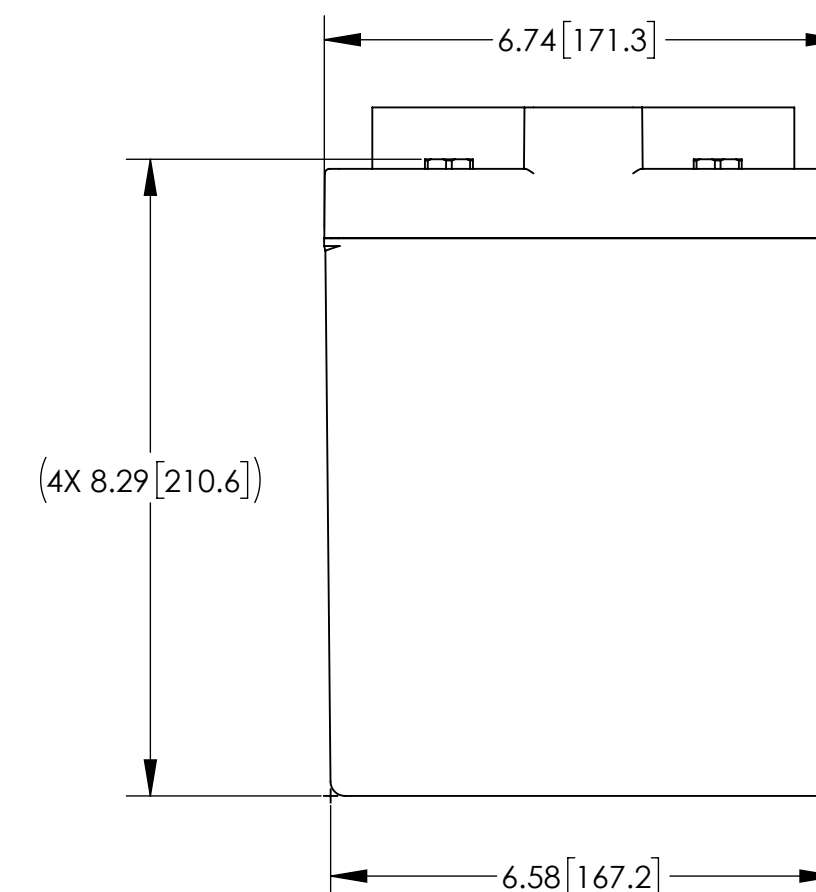
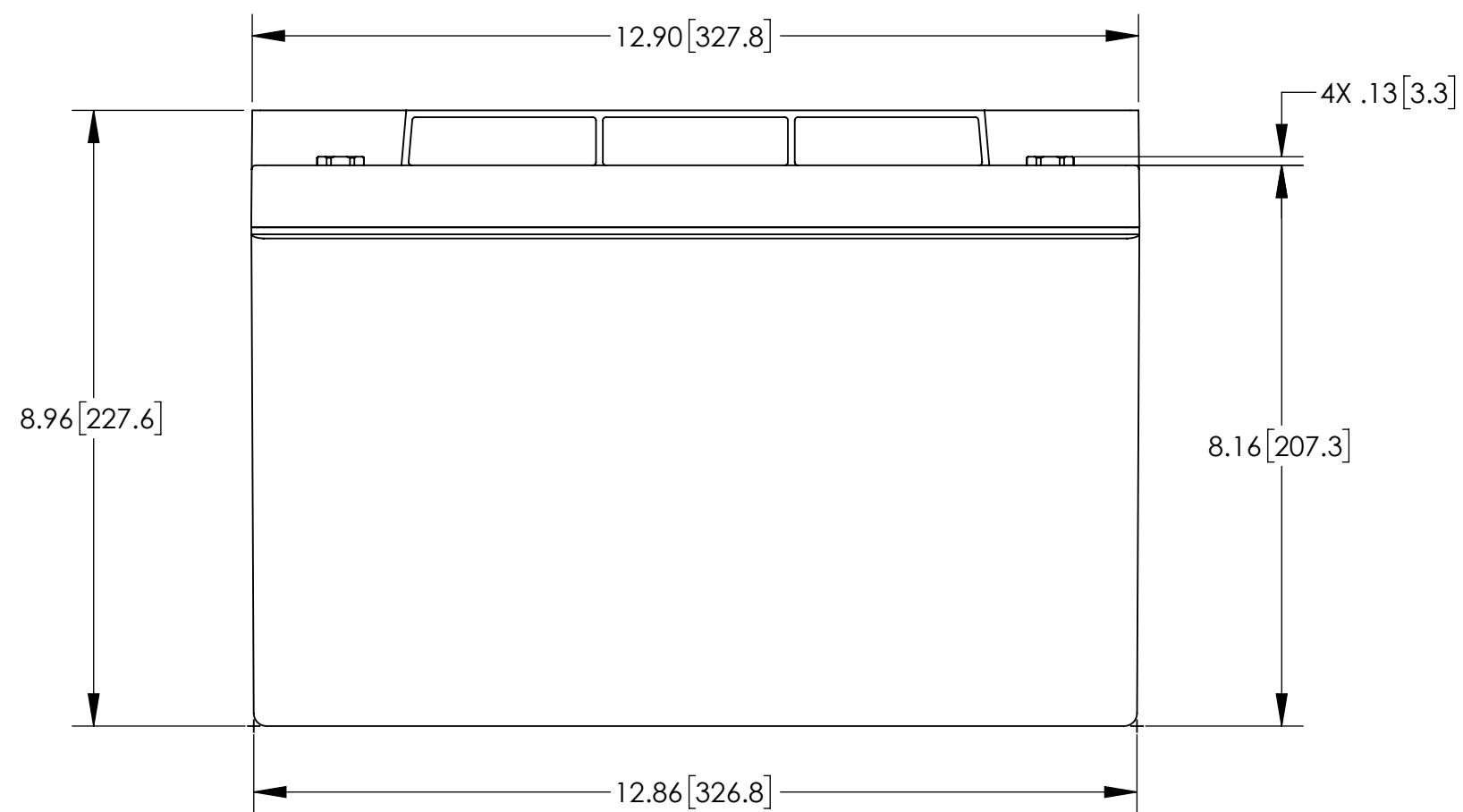

ENVELOPE DRAWING

CAPACITY RATINGS		
PART NUMBER	PVX-5340T	PVX-6480T
NOMINAL WEIGHT	64 LBS [29 KG]	67 LBS [30.5 KG]
AMPERE HOUR CAPACITY @ 24 HOUR 1.75 VOLTS/CELL @ 77°F (25°C)	534 AH	648 AH

UNLESS OTHERWISE SPECIFIED DIMENSIONS ARE IN INCHES TOLERANCES ARE:			CONTRACT NO.		CONCORDE BATTERY CORPORATION 2009 SAN BERNARDINO RD, W. COVINA, CA 91790					
FRACTIONS	DECIMALS	ANGLES	APPROVALS		DATE		TITLE			
±1/32	.XX ± .12 .XXX ± .060	±1°	DRAWN ELH		8/13/01		BATTERY, SLA, 2 VOLT, PVX-6480T SERIES			
TREATMENT	NONE		CHECKED HRF		8/21/01		SIZE	CAGE CODE	DWG NO.	REV
FINISH	NONE		APPROVED JBT		8/23/01		C	63017	PVX-6480T	D
SIMILAR TO	CALC WT		ISSUED DH		2/21/22		SCALE	1:2.5	SHEET 1 OF 1	