

NOTES: UNLESS OTHERWISE SPECIFIED

- SEE DRAWING NO. CB-00292 AND PROCEDURE P-1000 FOR ASSEMBLY AND TEST INSTRUCTION. PROCEDURES AND ASSEMBLY DRAWINGS ARE FOR INTERNAL USE ONLY.
- ALL TESTING IS PERFORMED IAW BATTERY COUNCIL INTERNATIONAL STANDARDS.
- DIMENSIONS ARE INCH [MILLIMETER].
- ABBREVIATION USED IN TITLE IS: SEALED LEAD ACID (SLA).
- TERMINAL HARDWARE KIT PROVIDED, PART NUMBER 6923 (2 REQD).

REVISIONS			
REV	DESCRIPTION	DATE	APPROVED
B	SEE DCN PVX6480TB	8/10/11	JBT
C	STANDARDIZED ENVELOPE, ADDED NOTE 5	7/29/20	PH

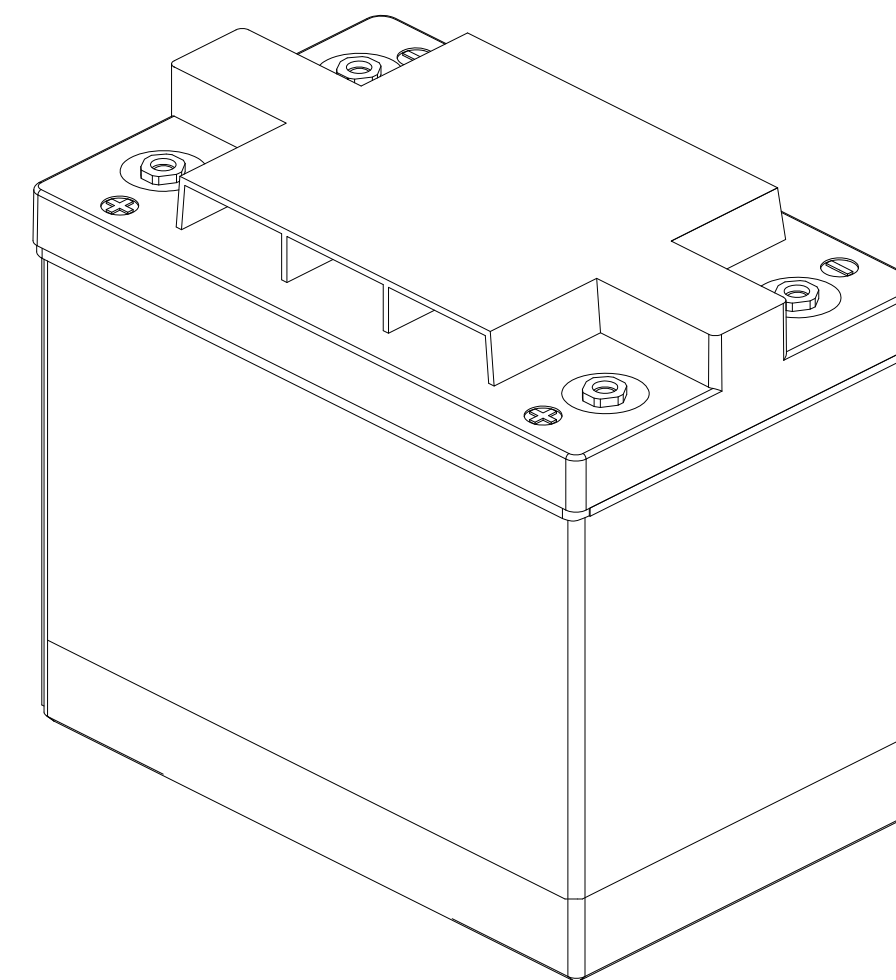
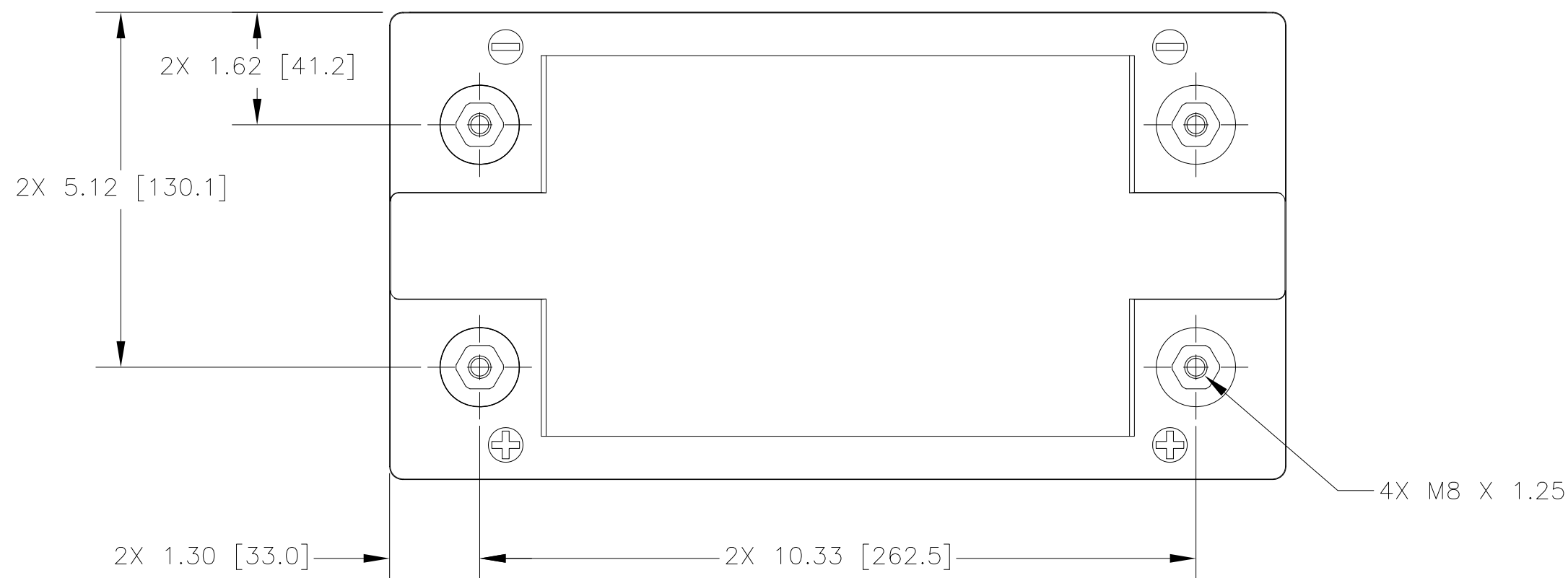

REFERENCE VIEW

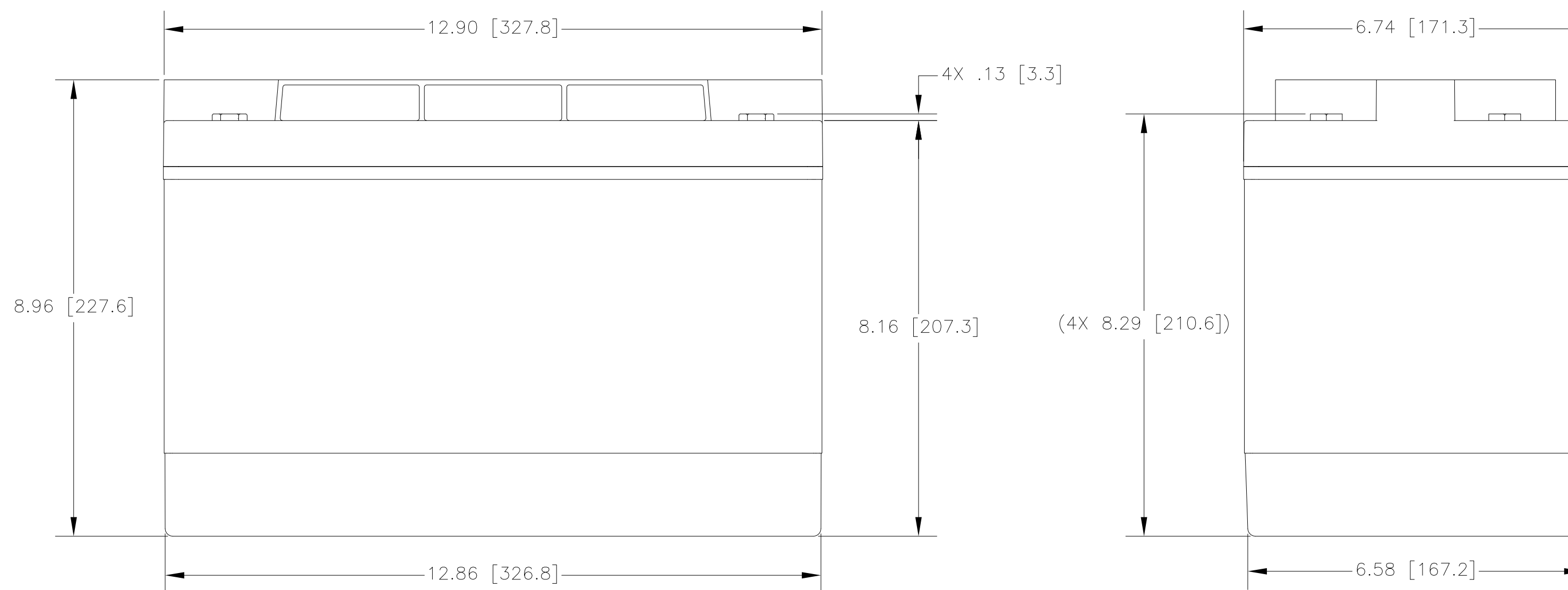

ENVELOPE DRAWING

CAPACITY RATINGS		
PART NUMBER	PVX-5340T	PVX-6480T
NOMINAL WEIGHT	64 LBS [29 KG]	67 LBS [30.5 KG]
AMPERE HOUR CAPACITY @ 24 HOUR 1.75 VOLTS/CELL @ 77°F (25°C)	534 AH	648 AH

QTY REQD	CAGE CODE	PART OR IDENTIFYING NO.	NOMENCLATURE OR DESCRIPTION	MATERIAL SPECIFICATION	ITEM NO.
PARTS LIST					
UNLESS OTHERWISE SPECIFIED DIMENSIONS ARE IN INCHES TOLERANCES ARE: FRACTIONS DECIMALS ANGLES ± 1/32 .XX ± .12 ± 1° .XXX ± .060			CONCORDE BATTERY CORPORATION 2099 SAN BERNARDINO RD, W. COVINA, CA 91790		
TREATMENT NONE			APPROVALS	DATE	TITLE
FINISH NONE			DRAWN ELH	8/13/01	BATTERY, SLA, 2 VOLT, PVX-6480T SERIES
SIMILAR TO			CHECKED HRF	8/21/01	SIZE
ACT WT			APPROVED JBT	8/23/01	CAGE CODE
CALC WT			ISSUED DH	7/30/20	DWG NO. PVX-6480T
			SCALE NONE		REV C
			SHEET 1 OF 1		