

NOTES: UNLESS OTHERWISE SPECIFIED

1. SEE DRAWING NO. CB-00293 AND PROCEDURE P-1000 FOR ASSEMBLY AND TEST INSTRUCTION. PROCEDURES AND ASSEMBLY DRAWINGS ARE FOR INTERNAL USE ONLY.
2. ALL TESTING IS PERFORMED IAW BATTERY COUNCIL INTERNATIONAL STANDARDS.
3. DIMENSIONS ARE INCH [MILLIMETER].
4. ABBREVIATION USED IN TITLE IS: SEALED LEAD ACID (SLA).
5. TERMINAL HARDWARE KIT PROVIDED, PART NUMBER 6932.

REVISIONS			
REV	DESCRIPTION	DATE	APPROVED
A	REVISED NOTE 1	8/29/16	PH
B	STANDARDIZED ENVELOPE, ADDED NOTE 5	7/28/20	PH

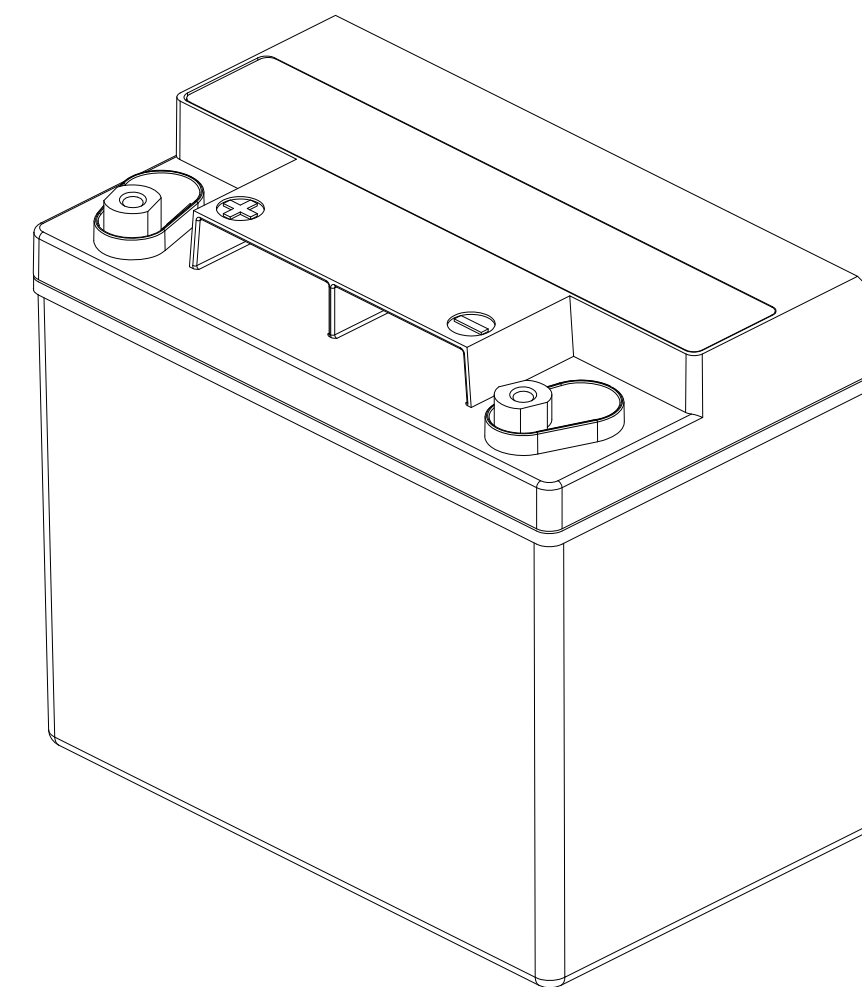
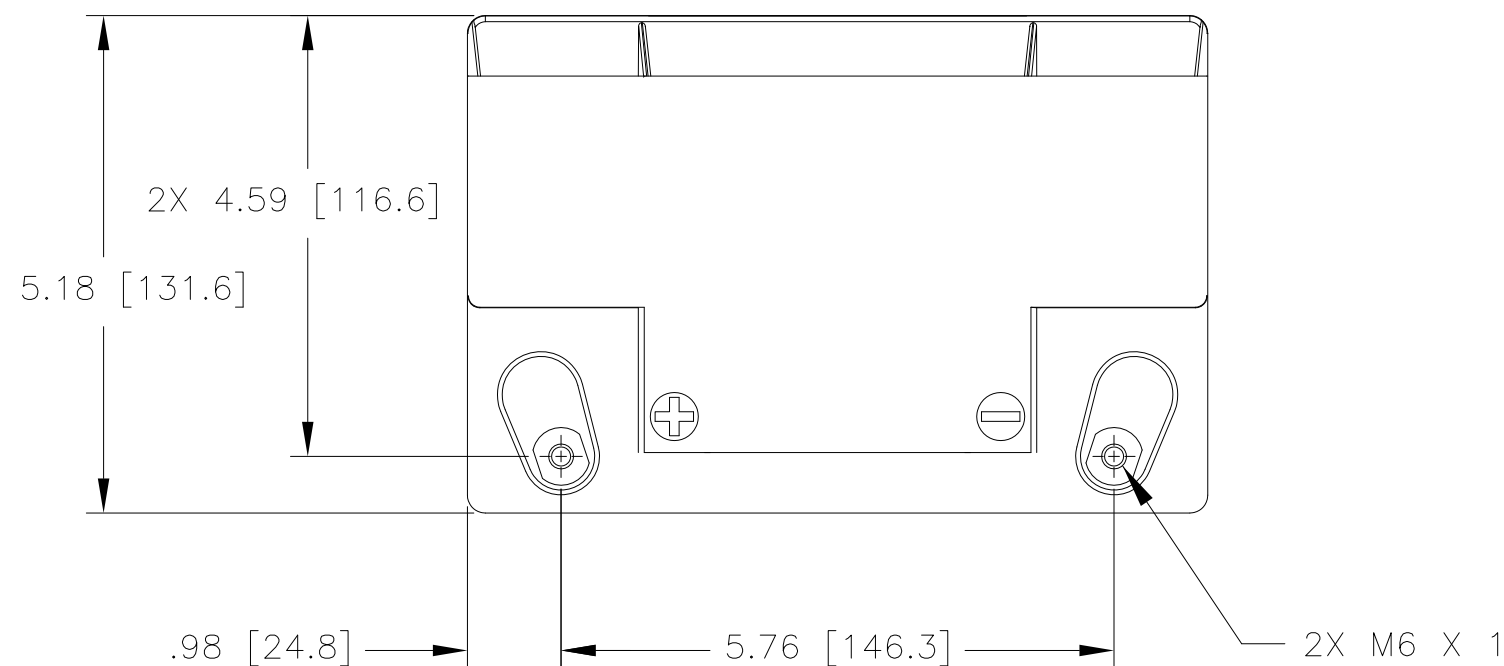

REFERENCE VIEW

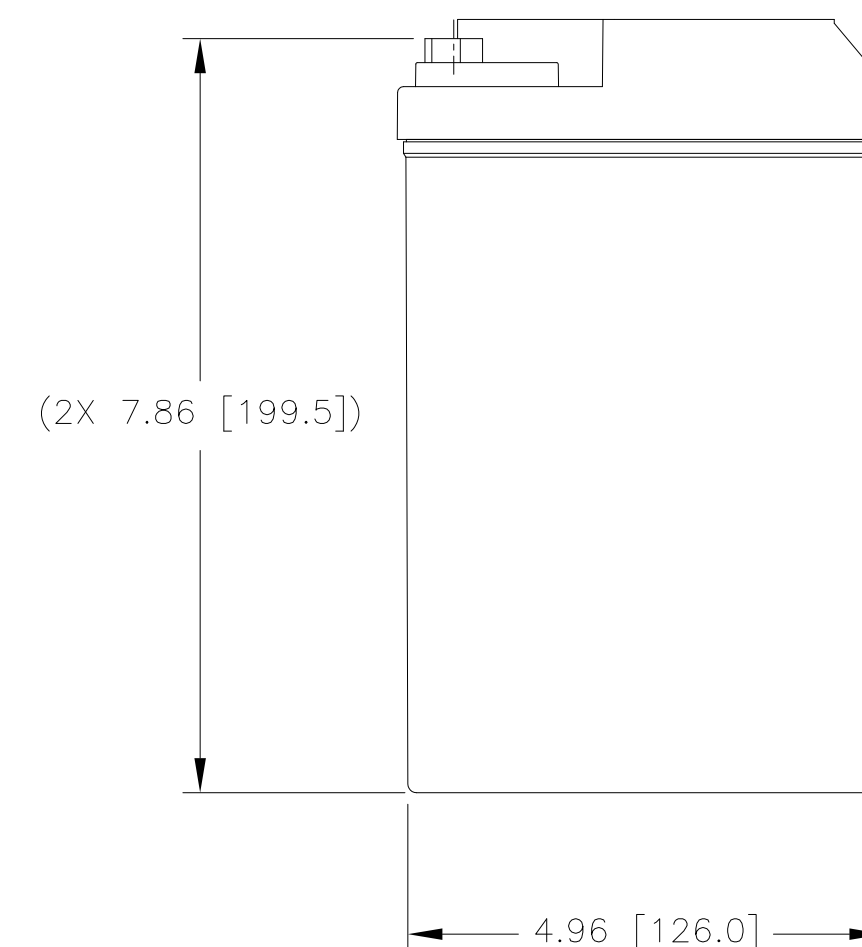
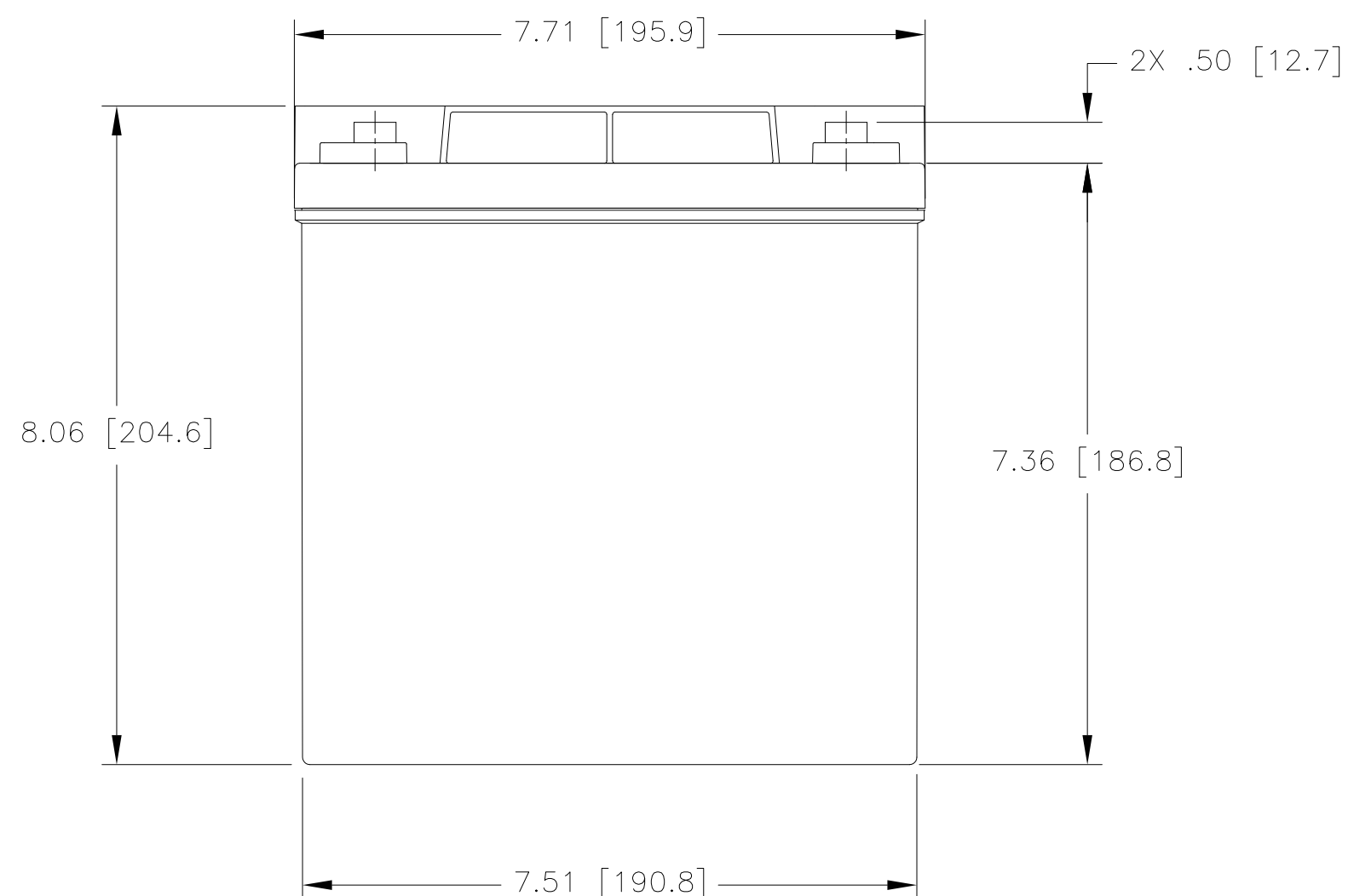

ENVELOPE DRAWING

CAPACITY RATINGS	
PART NUMBER	PVX-420T
NOMINAL WEIGHT	30 LBS[13.6 KG]
AMPERE HOUR CAPACITY @ 24 HOUR 1.75 VOLTS/CELL @ 77°F (25° C)	42 AH

QTY REQD	CAGE CODE	PART OR IDENTIFYING NO.	NOMENCLATURE OR DESCRIPTION	MATERIAL SPECIFICATION	ITEM NO.
PARTS LIST					
UNLESS OTHERWISE SPECIFIED DIMENSIONS ARE IN INCHES TOLERANCES ARE:			CONTRACT NO.		
FRACTIONS DECIMALS ANGLES			APPROVALS DATE		
± 1/32 .XX ± .12 ± 1°			DRAWN ELH 8/13/01		
.XXX ± .060			CHECKED HRF 8/20/01		
TREATMENT NONE			APPROVED JBT 8/23/01		
FINISH NONE			ISSUED DH 7/30/20		
SIMILAR TO			TITLE		
ACT WT CALC WT			CONCORDE BATTERY CORPORATION		
			2009 SAN BERNARDINO RD, W. COVINA, CA 91790		
			BATTERY, SLA, 12 VOLT, PVX-420T		
SIZE	CAGE CODE	DWG NO.	REV		
C	63017	PVX-420T	B		
SCALE	NONE	SHEET	1	OF	1