

NOTES: UNLESS OTHERWISE SPECIFIED

1. SEE DRAWING NO. CB-00290 AND PROCEDURE P-1000 FOR ASSEMBLY AND TEST INSTRUCTION. PROCEDURES AND ASSEMBLY DRAWINGS ARE FOR INTERNAL USE ONLY.
2. ALL TESTING IS PERFORMED IAW BATTERY COUNCIL INTERNATIONAL STANDARDS.
3. DIMENSIONS ARE INCH [MILLIMETER].
4. ABBREVIATION USED IN TITLE IS: SEALED LEAD ACID (SLA).
5. TERMINAL HARDWARE KIT PROVIDED, PART NUMBER 6923.

REVISIONS			
REV	DESCRIPTION	DATE	APPROVED
A	REDESIGNED COVER	12/19/17	PH
B	STANDARDIZED ENVELOPE, ADDED NOTE 5	7/29/20	PH
C	REVISED CONTAINER	12/16/21	PH

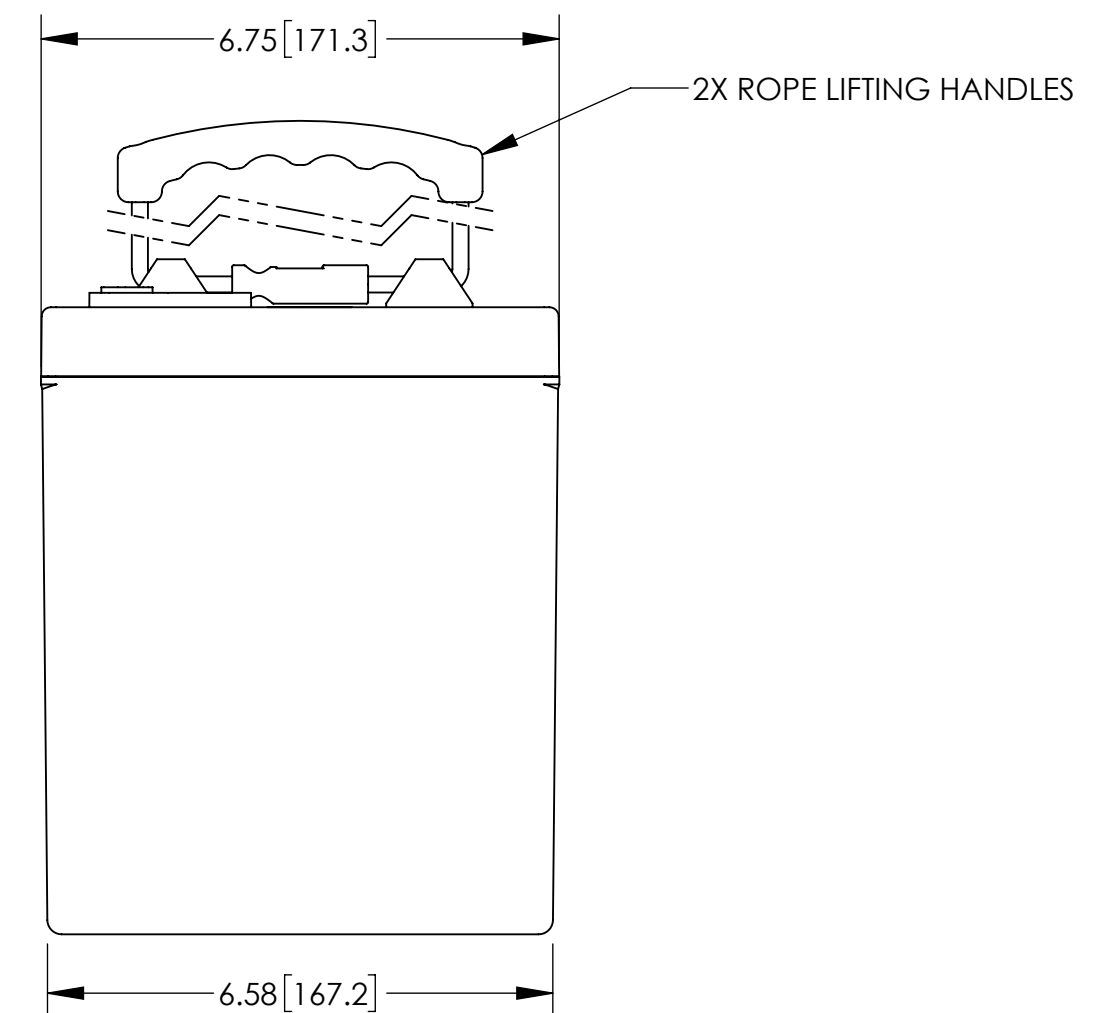
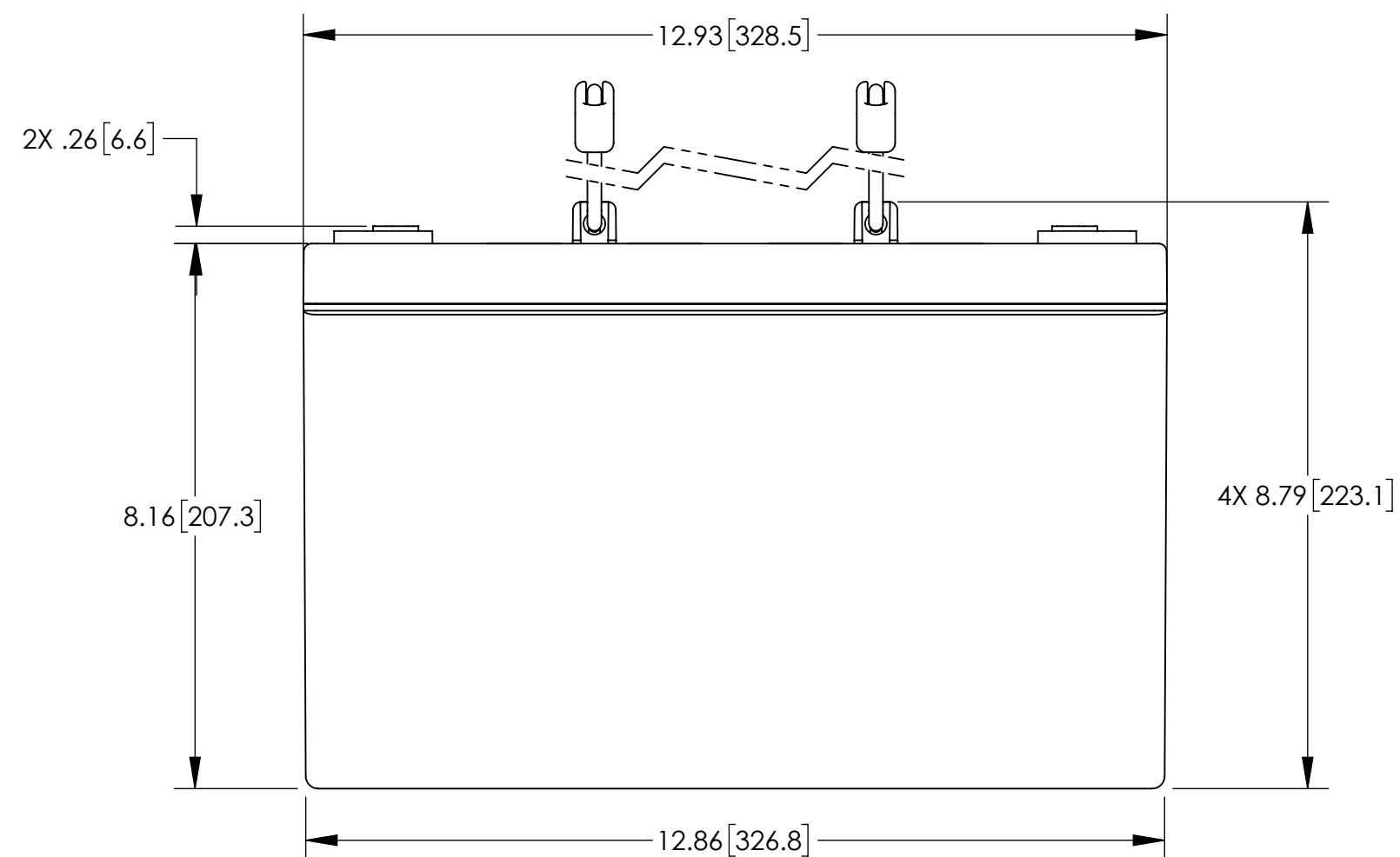
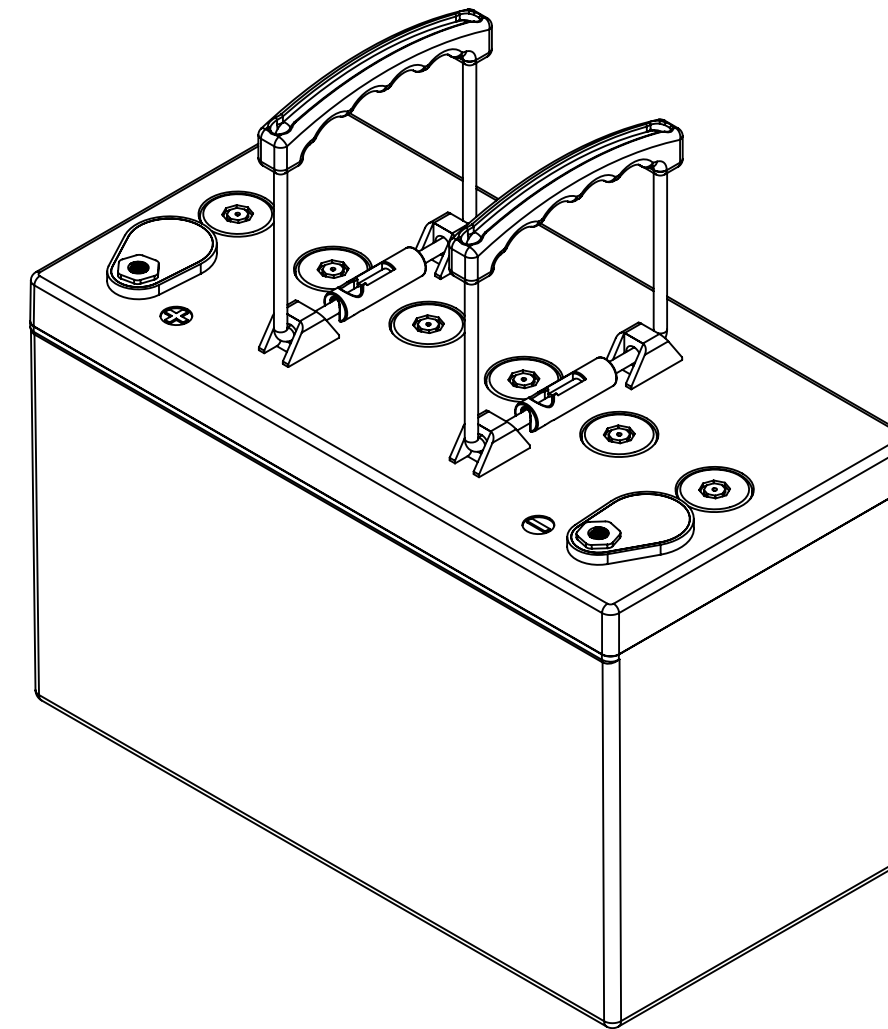
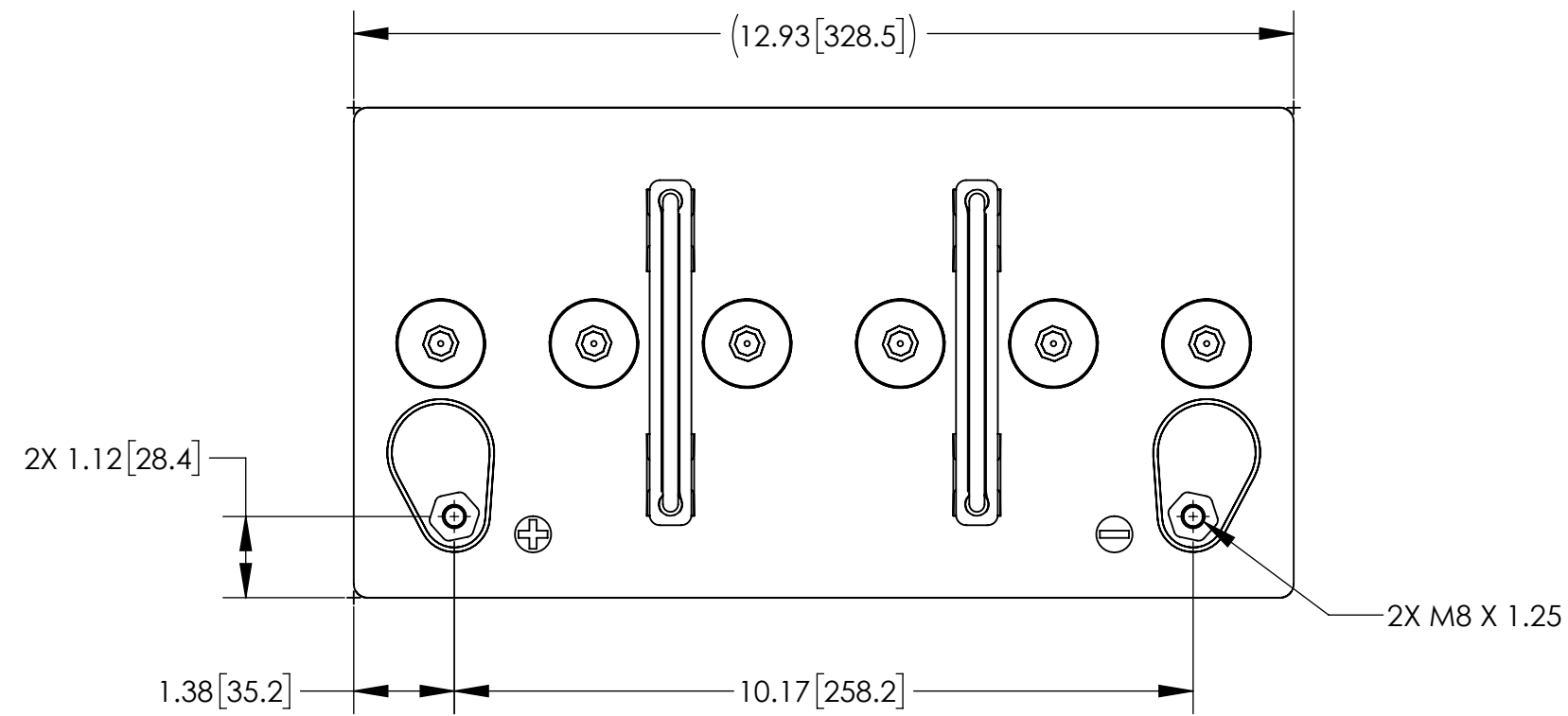

CAPACITY RATINGS	
PART NUMBER	PVX-1290T
NOMINAL WEIGHT	75 LBS [34.0 KG]
AMPERE HOUR CAPACITY @ 24 HOUR 1.75 VOLTS/CELL @ 77 °F (25°C)	129 AH

UNLESS OTHERWISE SPECIFIED DIMENSIONS ARE IN INCHES TOLERANCES ARE:			CONTRACT NO.		CONCORDE BATTERY CORPORATION 2009 SAN BERNARDINO RD, W. COVINA, CA 91790		
FRACTIONS	DECIMALS	ANGLES	APPROVALS	DATE	TITLE		
±1/32	.XX ± .12 .XXX ± .060	±1°	DRAWN D. AYALA	5/13/11	BATTERY, SLA, 12 VOLT, PVX-1290T		
TREATMENT	NONE	CHECKED AMIII	5/16/11	SIZE	CAGE CODE	DWG NO.	REV
FINISH	NONE	APPROVED DV	5/17/11	C	63017	PVX-1290T	C
SIMILAR TO	CALC WT	ISSUED DH	2/21/22	SCALE	1:2.5	SHEET	1 OF 1